



190 Queen Anne Ave N
PO Box 19028
Seattle, WA 98109-1028

REQUEST FOR BIDS (by Email)

Date: 7/18/19		To: Potential Bidders for SHA Solicitation No. 5244 Pedestrian Pathway Overhead Light Repairs Project	
The work described below is subject to the conditions described on Attachment A, version 1 <input checked="" type="checkbox"/> version 2 <input type="checkbox"/>			
SHA Reference No.: 5244	(Federal Prevailing Wages) Federal Wage Decision No.: HUD Non-Routine Maintenance March 25, 2019	OR	(State Prevailing Wages) Date of State Prevailing Wage Schedule: N/A
Number of Calendar Days to Complete Work: 5 days	For Questions Contact: Greg Antoine	Phone No.: (206) 615-3394 E-mail: purchasing@seattlehousing.org	
Project Description / Scope of Work: <input checked="" type="checkbox"/> See Scope of Work attached. <input type="checkbox"/> See Scope of Work below. Project Cost Estimate: \$22,000 - \$25,000			
PRE-BID SITE VISIT: <u>Wednesday, July 24, 2019 @ 10:00 AM</u> Location: 300 10 th Ave S, Seattle WA 98104 (South of Hoa Mai Gardens Community) DEADLINE FOR QUESTIONS is <u>Monday, July 29, 2019</u> no later than <u>1:00 PM</u> Email your questions to: purchasing@seattlehousing.org			
BID DUE DATE AND TIME: <u>Tuesday, August 6, 2019 by 1:00 PM.</u> The bidder is responsible for ensuring that its Bid is received prior to the deadline. Bids received after the deadline will not be considered. EMAIL YOUR BID TO: purchasing@seattlehousing.org or hand deliver to address: Seattle Housing Authority, 190 Queen Anne Ave N, Seattle WA 98109			
BIDDER ACKNOWLEDGES RECEIPT OF ADDENDA(S) NUMBER(S): _____			
BIDDER MUST COMPLETE THE INFORMATION BELOW. In addition, if bidder has never done business with SHA, it must submit a vendor fact sheet with its bid form. Bidder must also submit the required Section 3 forms with its bid form. <input checked="" type="checkbox"/> If checked, Bidder must complete the attached Detailed Bid Price Form and return with Request for Bids (by Email).			
Basic Bid Price (without Sales Tax) N/A	Sales Tax on Choose an item. N/A	Total Bid Price (with Sales Tax) N/A	
Bidder's Business Name:	Telephone No.:	E-Mail Address:	
Address:		City, State, Zip Code:	
Business Classification: <input type="checkbox"/> WBE <input type="checkbox"/> MBE <input type="checkbox"/> MWBE <input type="checkbox"/> Section 3		Contractor Registration No.:	
Signature:		Date:	Printed Name and Title of Person Signing Bid:
By signing above, the Bidder acknowledges receipt of Attachment A and any addenda issued for this project, and proposes to furnish all material and labor and to perform all work described herein for the Bid Price noted above. The Bidder also certifies the following: to have personally and carefully evaluated the Project Description / Scope of Work and Attachment A, and to have a clear understanding of the same, including the requirement to pay prevailing wages.			
SHADED AREA FOR USE BY SHA ONLY: Use this form only for projects estimated to cost less than \$150,000			
Required Number of Bids to Solicit for Federally Funded projects: Less than \$2,000: 1 bid \$2,001-\$150,000: 3 bids			
Required Number of Bids to Solicit for Non-Federally Funded projects: Less than \$10,000: 1 bid \$10,001-\$150,000: 5 bids			
See Purchasing policies for solicitation of projects \$150,000 and above.			

Seattle Housing Authority
Detailed Bid Price Form

Bidder's Check List

- 1) A bid must be submitted for each item listed below.
- 2) The Bidder's Business Name must be filled in below.
- 3) This "Detailed Bid Price Form" must be returned with the "Request for Bids (by EMAIL)" form.

SHA Reference No: 5244	Project Title: Pedestrian Pathway Overhead Light Repairs Project
---------------------------	---

Bidder's Business Name:

5 Pedestrian Pathway Overhead Lights On Property Owned by the City of Seattle (Sales tax on Labor and Materials)		
Basic Bid (Without Sales Tax)	Sales Tax on Labor & Materials	TOTAL COST Including Sales Tax on Labor & Materials

29 Pedestrian Pathway Overhead Lights On Property Owned by SHA (Sales Tax on Materials Only)		
Basic Bid (Without Tax)	Sales Tax on Materials Only	TOTAL COST Including Sales Tax on Materials Only

Total Lump Sum Cost: _____



Attachment A, Version 1

(Less than \$35,000)

Invitation to Bid (by EMAIL)

The work described in the Request for Bid (by Fax) is subject to the following terms and conditions:

Bidder Responsibility: The bidder must meet the mandatory bidder responsibility criteria described below and as specified in RCW 39.04 or 2 CFR 200 in order to be considered a responsible contractor and be eligible for award consideration:

1. At the time of bid submittal, have a current certificate of registration in compliance with chapter 18.27 RCW, which must have been in effect at the time of the bid submittal;
2. Have a current Washington Unified Business Identifier (UBI) number;
3. If applicable:
 - Have Industrial Insurance (workers' compensation) coverage for the bidder's employees working in Washington, as required in Title 51 RCW;
 - Have a Washington Employment Security Department number, as required in Title 50 RCW;
 - Have a Washington Department of Revenue state excise tax registration number, as required in Title 82 RCW;
 - Electrical Contractor License, if required by Chapter 19.28 RCW
 - Elevator Contractor License, if required by Chapter 70.87 RCW
4. Not be disqualified from bidding on any public works contract under RCW 39.06.010 or RCW 39.12.065(3).
5. Has not more than one violation of the off-site, prefabricated, non-standard, project specific items reporting requirements of RCW 39.04.370. (Applicable until December 31, 2013)
6. Has not been debarred, suspended, or otherwise ineligible to contract with SHA and is not included on the Excluded Parties List System (EPLS) on GSA's SAM (System for Award Management) <https://www.sam.gov/portal/public/SAM/> or the Department of Housing and Urban Development's "Limited Denial of Participation" list. This requirement also applies to the Bidder's principals.
7. Have completed training requirements under RCW 39.04.350 and RCW 39.06.020 before bidding on public works projects as determined by the Washington State Department of Industries **OR** have been in business with an active Unified Business Identifier (UBI) number for 3 or more years **AND** have performed work on 3 or more public works projects.

Prevailing Wages: The Contractor must pay all workers at least the prevailing wage rate for the type of work performed in accordance with the applicable prevailing wage rate schedule referenced on the Purchase Order or Request for Bid (by Fax) form and included in these solicitation documents. The type of wage schedule attached i.e., HUD Determined, Davis-Bacon, or the State Prevailing Wage schedule determines the appropriate labor standards that apply to the work as outlined below and contained in the General Conditions for Construction:

- 1) Part 11.13 for projects subject to the HUD-Determined wage rate schedule.
- 2) Part 11.12 for projects subject to Davis-Bacon wage schedule.
- 3) Part 5 for projects subject to the State prevailing wage schedule.

As part of its compliance with the prevailing wage requirements, the Contractor and, if applicable, subcontractor(s) shall comply with the requirement to submit a Statement of Intent to Pay Prevailing Wages and Affidavit of Wages Paid forms approved by the State of Washington's Department of Labor and Industries. The Owner will notify the Contractor of any special filing instructions that may apply for these forms depending on the funding source(s) of the project.

Bid Bond: SHA does not require a bid guarantee for small works roster construction projects estimated to cost \$150,000 or less.

Insurance: Within seven calendar days of award, the Contractor shall submit to SHA, and maintain throughout the contract, at no expense to SHA, the following insurance coverage at the limits noted (refer to SHA's General Conditions for more details):

1. Commercial General Liability Insurance. \$1,000,000 each occurrence, and \$2,000,000 aggregate
2. Additional Insured Endorsement Ongoing Operations: The Owner must be included as an Additional Insured on a primary and non-contributory basis on all Commercial General Liability policies of the Contractor. A policy endorsement form CG2010 or equivalent must be provided to Owner as evidence of additional insured coverage.
3. Additional Insured Endorsement Completed Operations: The Contractor's CGL insurance shall include the Owner as an additional insured for Contractors Completed Operations by providing additional insured status on the CG2037 endorsement, or by an equivalent policy or endorsement provision. The Contractors Completed Operations additional insured status for the Owner shall remain in effect for not less than three (3) years following the Final Acceptance of the Work by the Owner.
4. Employers Liability policy or Washington Stop Gap Liability insurance endorsement: \$1,000,000 each accident
5. Workers Compensation coverage.
6. Commercial Automobile Liability Insurance. \$1,000,000 combined single limit coverage

No Contract Bond: Consistent with the requirements of State law (RCW 39.04.155), SHA is not requiring a Contract Payment and Performance Bond.

Retainage Requirements: SHA will retain five(5) percent of the contract amount for a period of thirty days after date of final acceptance, or until receipt of all necessary releases from the department of revenue, the employment security department, and the department of labor and industries and settlement of any liens filed under chapter [60.28](#) RCW, whichever is later.

Tax Exempt Status of SHA: For this project, SHA is subject to sales tax for materials, labor and services rendered. The Contractor must pay sales tax on a total of 34 pedestrian light repairs as follows:

- 29 pedestrian lights - SHA will reimburse for sales tax on materials/parts (minimal).
- 5 pedestrian lights - SHA will reimburse for sales tax on materials and labor.

Protests: Any protest of award shall be resolved in accordance with SHA's Procurement Policies, which may be reviewed at [SHA website](#).

General Conditions: SHA's General Conditions are hereby incorporated by reference and made a part of this Request for Bid (by Fax) and any subsequent contract or purchase order executed for this work as if fully included herein. If the event of any discrepancy between the terms of this Attachment A and the General Conditions, the terms of the General Conditions shall apply, except that the types and amounts of insurance specified above, and the waiver of the Contract Bond and withholding of retainage specified above, shall take precedence over the General Conditions. The General Conditions may be viewed by accessing [SHA website](#), or upon request, a copy of the General Conditions may be obtained by calling SHA at (206) 615-3379.

Performance Evaluation: The Contractor's performance on this project will be evaluated in accordance with SHA's Contractor Performance Evaluation Program. A copy of the Program may be obtained by accessing [SHA website](#).

Section 3: Section 3 of the Housing and Urban Development Act of 1968 (hereinafter "Section 3") requires SHA to the greatest extent feasible to provide employment opportunities to Section 3 residents. Section 3 residents include residents of SHA communities and other low-income residents of the metropolitan statistical area (MSA) covering King, Snohomish, and Pierce counties. Each bidder is required to submit with its Bid a Section 3 Resident Employment Plan that will result in hiring Section 3 residents to perform the work

contemplated by this invitation to bid, and a Section 3 Business Certification form. Failure to complete these forms may render a bid non-responsive.

- A. Selection Preference for Section 3 Businesses: If the bidder claims to be a Section 3 business on the Section 3 Business Certification form required to be submitted with the Bid, and the Bid of the Section 3 business exceeds the low bid by no more than 10%, SHA will conduct an investigation whether the business qualifies as a Section 3 business, and SHA may award the contract to the Section 3 business at the price bid by the Section 3 business. In submitting a Bid, the bidder agrees to provide any information required by SHA to determine whether the business qualifies as a Section 3 business. A business may qualify as a Section 3 business by meeting one of the following criteria:
1. At least 51% of the business is owned by Section 3 qualified persons who live in the metropolitan statistical area (MSA) covering King, Snohomish, and Pierce counties and meet the prescribed income limitations based on family size as shown on the Section 3 Business Certification form.
 2. 30% or more of the business' permanent, full-time employees (core employees within the last 12 months) are Section 3 qualified persons who live in the metropolitan statistical area (MSA) covering King, Snohomish, and Pierce counties and meet the prescribed income limitations based on family size as shown on the Section 3 Business Certification form.
 3. The business makes a commitment to subcontract with Section 3 businesses for more than 25% of the dollar amount of all subcontracts to be awarded by the business. Prior to award, such businesses must submit a plan and the necessary support documents describing how the subcontracting commitment will be met. SHA will evaluate the plan and documents submitted and determine whether it is likely the bidder will attain the subcontracting percentage. SHA will monitor the Section 3 business' compliance with their subcontracting commitment. The bidder's failure to fulfill the Section 3 subcontracting commitment shall be a material breach of contract which may result in SHA taking any or all of the following actions: (1) demanding specific performance of the subcontracting plan; (2) withholding from contract payments the dollar amount of any or all subcontracts that were to have been awarded to Section 3 businesses or such lesser amount as may be appropriate; (3) withholding any liquidated damages that SHA may incur as a result of the bidder's failure to comply with its Section 3 commitment and subcontracting plan; and (4) declaring the bidder ineligible to compete for, or participate in, any SHA contract for a period of five years from the acceptance date of the contract in which the Section 3 subcontracting commitment was made.
- B. Section 3 Contract Language: The following language regarding Section 3 will be included as part of the contract to be executed based on this invitation to bid.
1. The work to be performed under this contract is subject to the requirements of Section 3 of the Housing and Urban Development Act of 1968, as amended, 12 U.S.C. 1701u (Section 3). The purpose of Section 3 is to ensure that employment and other economic opportunities generated by HUD assistance or HUD-assisted projects covered by Section 3, shall, to the greatest extent feasible, be directed to low- and very low-income persons, particularly persons who are recipients of HUD assistance for housing.
 2. The parties to this contract agree to comply with HUD's regulations in 24 CFR part 135, which implement Section 3. As evidenced by their execution of this contract, the parties to this contract certify that they are under no contractual or other impediment that would prevent them from complying with the part 135 regulations.
 3. The contractor agrees to send to each labor organization or representative of workers with which the contractor has a collective bargaining agreement or other understanding, if any, a notice advising the labor organization or workers representative of the contractors commitments under this Section 3 clause, and will post copies of the notice in conspicuous places at the work site where both employees and applicants for training and employment positions can see the notice. The notice shall describe the Section 3 preference, shall set forth minimum number and job titles subject to hire, availability of apprenticeship and training positions, the qualifications for each; and

the name and location of the person(s) taking applications for each of the positions; and the anticipated date the work shall begin.

4. The contractor agrees to include this Section 3 clause in every subcontract subject to compliance with regulations in 24 CFR part 135, and agrees to take appropriate action, as provided in an applicable provision of the subcontract in this Section 3 clause, upon a finding that the subcontractor is in violation of the regulations in 24 CFR part 135. The contractor will not subcontract with any subcontractor where the contractor has notice or knowledge that the subcontractor has been found in violation of the regulations in 24 CFR part 135.
5. The contractor will certify that any vacant employment positions, including training positions, that are filled (1) after the contractor is selected but before the contract is executed, and (2) with persons other than those to whom the regulations of 24 CFR part 135 require employment opportunities to be directed, were not filled to circumvent the contractor's obligations under 24 CFR part 135.
6. Noncompliance with HUD's regulations in 24 CFR part 135 may result in sanctions, termination of this contract for default, and debarment or suspension from future HUD assisted contracts.
7. With respect to work performed in connection with Section 3-covered Indian Housing Assistance, Section 7(b) of the Indian Self-Determination and Education Assistance Act (25 U.S.C. 450e) also applies to the work to be performed under this Contract. Section 7(b) requires that to the greatest extent feasible (i) preference and opportunities for training and employment shall be given to Indians, and (ii) preference in the award of contracts and subcontracts shall be given to Indian organizations and Indian-owned Economic Enterprises. Parties to this Contract that are subject to the provisions of Section 3 and Section 7(b) agree to comply with Section 3 to the maximum extent feasible, but not in derogation of compliance with Section 7(b).
8. If the Contractor is a Section 3 business and was awarded the contract by SHA based on the Section 3 business preference requirements of the invitation to bid for committing to subcontract more than 25% of the dollar amount of all subcontracts to Section 3 businesses, the Contractor agrees to meet the Section 3 subcontracting commitment. Failure of the Contractor to fulfill the Section 3 subcontracting commitment shall be deemed a material breach of contract, which may result in SHA taking any or all of the following actions: (1) demanding specific performance of the subcontracting plan; (2) withholding from contract payments the dollar amount of any or all subcontracts that were to have been awarded to Section 3 businesses or such lesser amount as may be appropriate, (3) withholding any liquidated damages that SHA may incur as a result of the Contractor's failure to comply with its Section 3 commitment and subcontracting plan; and (4) declaring the Contractor ineligible to compete for, or participate in, any SHA contract for a period of five years from the acceptance date of the contract in which the Section 3 subcontracting commitment was made.

SOLICITATION 5244
PEDESTRIAN PATHWAY OVERHEAD LIGHT REPAIRS PROJECT

SCOPE OF WORK

SHA is seeking a qualified licensed electrician to troubleshoot and repair 34 – 3Rivers Pedestrian light fixtures located in the areas from Jackson Street to Fir Street including the Yesler Hill Climb area, the west side of the Hoa Mai Gardens apartment building, the pathway through Yesler Terrace Park, and the pathway between the Raven Terrace and Batik apartment buildings. The work will require working at 16-17 feet in height and cordoning off areas about a 6-8 feet radius for public safety.

The work shall consist of:

1. Per specification, verify and tighten all screws, nuts, and bolts, including the adjustable support arm and deflective panel on the light poles.
2. Replace 2 adjustable support arms and 2 deflective panels on light poles as needed.
3. Replace approximately 14 LED's, 17 ballasts on light poles as needed.

Selected Contractor shall:

1. Evaluate all 3River Pedestrian light pole fixtures
2. Use SHA supplied materials as needed
3. Provide lifting equipment, tools or other appropriate means to accessing the light pole fixtures at no additional cost to SHA

SHA shall:

1. Provide all materials and replacement parts
2. Order additional replacement parts
3. Provide parking

Project Cost Estimate: \$22,000 - \$25,000

Notes:

- 3River Pedestrian Product Data is attached and can also be found at:
<https://www.forms-surfaces.com/3rivers-pedestrian-lighting>



3RIVERS™ PEDESTRIAN

PRODUCT DATA





3RIVERS™ PEDESTRIAN

PRODUCT DATA

3Rivers is an indirect pedestrian fixture whose beautiful design is both dramatic and understated. The oval cross-section pole and oval-shaped reflective panel gives 3Rivers a clean, streamlined look that's at home in a wide range of architectural and landscape settings. All components are rustproof aluminum. Striking in form and exceptionally durable, 3Rivers is a great lighting option for walkways, parks, malls, campuses, and other public spaces.

MATERIAL & CONSTRUCTION DETAILS

INSTALLATION & MAINTENANCE

POLE	FINISH	LAMP	INSTALLATION
<ul style="list-style-type: none"> 6" x 9" (152 mm x 229 mm) oval-shaped heavy wall extruded aluminum with gasketed hand hole. Overall height of pole is 166" (4216 mm). 	<ul style="list-style-type: none"> See the Forms+Surfaces Powdercoat Chart for details. Custom RAL colors are available for an upcharge. Due to the inherent nature of metal castings, gloss powdercoats are not offered for cast components. 	<ul style="list-style-type: none"> Features advanced LED technology with 50W, 3000K warm white and 4000K neutral white LEDs. LED chip is mounted to an extruded aluminum heat sink. 	<ul style="list-style-type: none"> 0.75" thick structural aluminum base plate with cast aluminum base cover and 3/4"-10x24" galvanized steel J-bolt anchors. Installation of a surge protector as part of each units wiring is recommended. Necessary hardware is included. Template is available upon request.
REFLECTIVE PANEL	WEIGHT	DRIVER	MAINTENANCE
<ul style="list-style-type: none"> 29" x 42" (737 mm x 1067 mm) 1/2" (13 mm) thick oval-shaped aluminum with integral drip edge. Bottom surface is finished in white for maximum reflectivity. Panel is supported by adjustable cast aluminum arm (standard angle is 15° above horizontal). 	<ul style="list-style-type: none"> 216 lbs (98 kg) 	<ul style="list-style-type: none"> LED driver input power is 100/277 VAC. LED driver certifications include: IP66 & NEMA6 (waterproof) enclosure, and Class 2 rated output (UL8750) 	<ul style="list-style-type: none"> Metal surfaces can be cleaned as needed using a soft cloth or brush with warm water and a mild detergent. Avoid abrasive cleaners.

NOMINAL DIMENSIONS

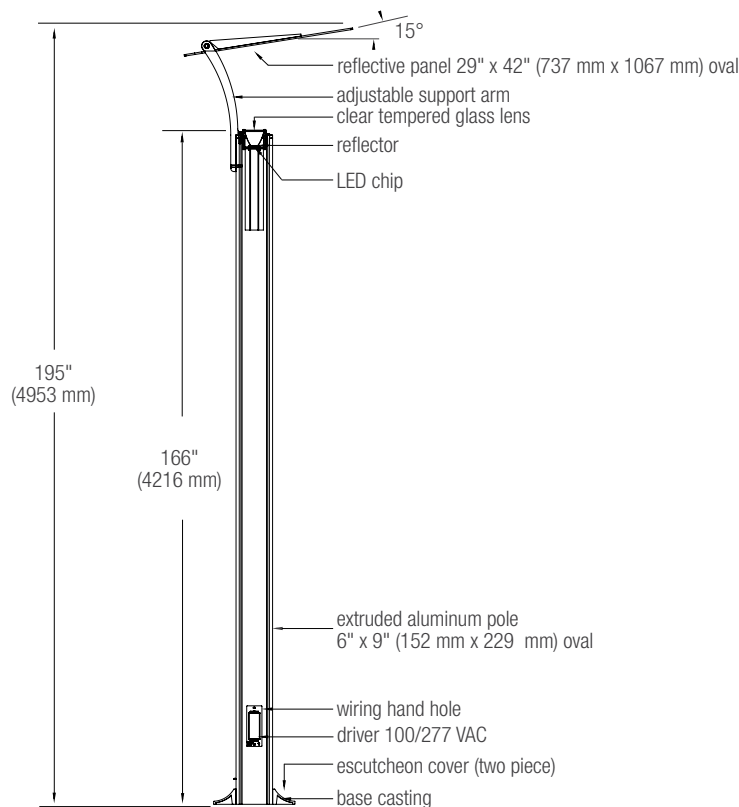

BASE PLATE MOUNTING DETAIL

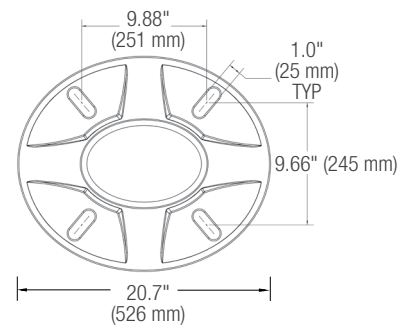

T 800.451.0410 | www.forms-surfaces.com

FORMS+SURFACES®

© 2018 Forms+Surfaces® | All dimensions are nominal. Specifications and pricing subject to change without notice. For the most current version of this document, please refer to our website at www.forms-surfaces.com.



3RIVERS™ PEDESTRIAN

PRODUCT DATA

LAMP DESCRIPTIONS

LAMP	DESCRIPTION	COLOR TEMPERATURE	LUMINAIRE LUMENS*	B.U.G. RATING	STARTING TEMPERATURE °C
LED 3000K	50W LED chip	3000K	2392	B1-U2-G1	-30
LED 4000K	50W LED chip	4000K	2705	B1-U3-G1	-30

*Luminaire lumens represents the absolute photometry for the luminaire, and indicates the lumens out of the entire fixture.

NOTE: Polar candela and isofootcandle plots can be found on the Light Column Pedestrian product page on our website.

CERTIFICATION

- UL and C-UL listed for wet locations.
- ETL and C-ETL listed for wet locations.

ENVIRONMENTAL CONSIDERATIONS

- Please refer to the 3Rivers Pedestrian Environmental Data Sheet for detailed environmental impact information.
- 3Rivers Pedestrian has a high recycled content and is highly recyclable.
- Powdercoat finishes are no- or low-VOC, depending on color.
- Low maintenance.

MODEL NUMBERS AND DESCRIPTIONS

MODEL	DESCRIPTION
LPRIV-LED	3Rivers Pedestrian, LED

PRODUCT OPTIONS

The following options are available for an upcharge

Premium Texture Colors from Forms+Surfaces Powdercoat Chart
Custom RAL powdercoat color

LEAD TIME: 6 to 8 weeks. Shorter lead times may be available upon request. Please contact us to discuss your specific timing requirements.

PRICING: Please contact us at **800.451.0410** or **sales@forms-surfaces.com**. At Forms+Surfaces, we design, manufacture and sell our products directly to you. Our sales team is available to assist you with questions about our products, requests for quotes, and orders. Territory Managers are located worldwide to assist with the front-end specification and quoting process, and our in-house Project Sales Coordinators follow your project through from the time you place an order to shipment.

TO ORDER SPECIFY: Quantity, model, powdercoat color, lamp, voltage. Quote/Order Forms are available on our website to lead you through the specification process in a simple checkbox format.

Contract No. 5244

CONSTRUCTION AND MAINTENANCE SERVICES

for

Pedestrian Pathway Overhead Light Repairs Project

This Contract is made and entered into as of the last signature date below between the Seattle Housing Authority, a public body corporate and politic, hereinafter referred to as "Owner," and _____, hereinafter referred to as the "Contractor." The Contractor and the Owner agree as follows:

SECTION 1: This Contract incorporates by reference and is subject to the following as though fully included herein, whether attached or not attached:

- The Contractor's response to the Request for Bids (by EMAIL) (attached)
- Attachment A, version 1 (attached)
- Technical scope of work included as part of the Request for Bids (by EMAIL)
- Owner's General Conditions
- Prevailing wage rates as established in Select One dated _____ (attached)

SECTION 2: The Contractor shall perform or cause to be performed all work and shall furnish or cause to be furnished all labor, materials, tools, and equipment necessary to complete the above-referenced project in strict accordance with the Contract Documents and documents described in Section 1 above for the following Contract Sum:

Base Bid	\$
Sales Tax	\$
Contract Sum	\$

SECTION 3: The Contractor shall begin the work of the Contract immediately after receipt of a written Notice to Proceed issued by the Owner, and to perform the work regularly and without interruption thereafter (unless the Owner shall otherwise, in writing, specifically direct) with such forces as necessary to complete said work in a manner acceptable to the owner within _____ consecutive calendar days from the date of the Notice to Proceed.

The parties have executed this Contract by having their authorized representatives sign below.

Seattle Housing Authority
190 Queen Anne Avenue North
P.O. Box 19028
Seattle, WA 98109-1028

By: _____
Date

By: _____
Date
Contracts & Procurement Manager

Maintenance Wage Rate Decision**U.S. Department of Housing and
Urban Development
Office of Labor Relations****HUD FORM 52158****(06/2006)**

Agency Name:

**Seattle Housing Authority
190 Queen Anne North
Seattle, WA 98109**

LR 2000 Agency ID No:

WA002A

Wage Decision Type:

-
- Routine Maintenance
-
-
- Nonroutine Maintenance

Effective Date:

March 25, 2019

Expiration Date:

December 31, 2020

The following wage rate determination is made pursuant to Section 12(a) of the U.S. Housing Act of 1937, as amended, (public housing agencies), or pursuant to Section 104(b) of the Native American Housing Assistance and Self-determination Act of 1996, as amended, (Indian housing agencies). The agency and its contractors may pay to maintenance laborers and mechanics no less than the wage rate(s) indicated for the type of work they actually perform.

Eugene Hairston, SLRS**HUD Labor Relations
(Name, Title, Signature)****3-25-2019****Date****WORK CLASSIFICATION(S)****HOURLY WAGE RATES****BASIC WAGE****FRINGE BENEFIT(S) (if any)**

Elevator Mechanic	\$56.28	\$22.51
Sheet Metal Worker	\$29.30	\$15.75
Furnace Installer	\$28.83	\$15.63
Roofer	\$27.71	\$15.35
Truck Driver	\$23.91	\$14.40
Laborer	\$22.71	\$16.10
Asphalt Raker	\$19.35	\$13.26
Carpenter	\$28.42	\$18.31
Electrician	\$32.07	\$19.15
Floor Coverer	\$23.07	\$17.04
Glazier	\$26.99	\$18.22
Painter	\$18.82	\$17.04
Low Voltage Technician	\$26.39	\$15.02
Plumber	\$33.17	\$19.15
Tree Arborist	\$26.67	\$15.09
Landscaper	\$16.96	\$14.37
Fence Installer	\$20.83	\$13.63
Power Equipment Operator	\$34.12	\$16.96
Brick Mason	\$29.80	\$15.87

-
- The agency employee benefit program has been determined by HUD to be acceptable for meeting the prevailing fringe benefit requirements.

(HUD Labor Relations: If applicable, check box and initial below.)

LR Staff Initial**FOR HUD USE ONLY****LR2000:****Log in:****Log out:**

Maintenance Wage Rate Decision

**U.S. Department of Housing and Urban Development
Office of Labor Relations**

**HUD FORM 52158
(06/2006)**

Agency Name:
**Seattle Housing Authority
190 Queen Anne North
Seattle, WA 98109**

LR 2000 Agency ID No:
WA002A

Effective Date:
March 25, 2019

Wage Decision Type:
 Routine Maintenance
 Nonroutine Maintenance

Expiration Date:
December 31, 2020

The following wage rate determination is made pursuant to Section 12(a) of the U.S. Housing Act of 1937, as amended, (public housing agencies), or pursuant to Section 104(b) of the Native American Housing Assistance and Self-determination Act of 1996, as amended, (Indian housing agencies). The agency and its contractors may pay to maintenance laborers and mechanics no less than the wage rate(s) indicated for the type of work they actually perform.

Eugene Hairston, SLRS

6/27/2019

**Revised
Date**

HUD Labor Relations
(Name, Title, Signature)

WORK CLASSIFICATION(S)	HOURLY WAGE RATES	
	BASIC WAGE	FRINGE BENEFIT(S) (if any)
continued - Page 2		
Pipe Layer	\$34.91	\$17.15
Vehicle Mechanic	\$23.39	\$17.77
Engineer	\$41.54	\$19.15
Pest Control Technician	\$22.27	\$17.05
Solid Waste Laborer	\$18.05	\$16.24
Solid Waste Vehicle Mechanic	\$28.82	\$18.23
Solid Waste Worker, CDL	\$20.06	\$18.57
Window cleaner:		
Scaffold	\$15.99	\$12.41
Non-Scaffold	\$15.99	\$12.41
Flagger	\$22.71	\$16.10
		<input type="checkbox"/> The agency employee benefit program has been determined by HUD to be acceptable for meeting the prevailing fringe benefit requirements. (HUD Labor Relations: If applicable, check box and initial below.) _____ LR Staff Initial

FOR HUD USE ONLY
LR2000:

Log in:

Log out:

FORMS TO BE COMPLETED AND RETURNED WITH BID FORM

- Vendor Fact Sheet
- Section 3 Business Certification & Resident Employment Plan
- Suspension and Debarment Compliance Certificate for Contractor and Subcontractors
- For Profit Subgrantee and Contractor Certifications and Assurances
- Certification of Compliance with Wage Payment Statutes



VENDOR FACT SHEET

Return this Form TO: Seattle Housing Authority, Purchasing Division,
ATTN: Greg Antoine
190 Queen Anne Ave N, P.O Box 19028, Seattle WA 98109-1028

General Business Information:

Name of Business, Organization, or Name of Person (if payment is to an individual):

For SHA Use Only:

JDE Vendor No.

Purchasing contracts

Mailing Address for Payments:

City:

State:

Zip Code:

E-Mail Address:

Telephone No.:

Fax No.:

DUNS No.:

Washington UBI No.:

City of Seattle Business License No.:

Washington Contractor's License No.:

President/General Manager:

Principal products and/or services offered:

Type of Organization (check one):

Individual

Sole Proprietor

Partnership

Corporation

Governmental Agency

Other _____

Employee Tax ID No. (TIN) or Social Security No. (if Individual):

Substitute IRS Form W-9 Certification:

Under penalties of perjury, I hereby certify that the number shown on this form is my correct taxpayer identification number, and that I am not subject to backup withholding because: (a) I am exempt from backup withholding, or (b) I have not been notified by the Internal Revenue Service (IRS) that I am subject to backup withholding as a result of a failure to report all interest or dividends, or (c) the IRS has notified me that I am no longer subject to backup withholding, and I am a U.S. person (including a U.S. resident alien). **Note:** The Internal Revenue Service does not require your consent to any provision of this document other than the certifications required to avoid backup withholding.

**SIGN
HERE →**

Signature of U.S. Person

Date

Ownership Status (check all that apply):

- MBE** (Minority-Owned Business Enterprise)
 WBE (Women-Owned Business Enterprise)
 MWBE(Minority / Women-Owned Business Enterprise)
 CBE (Combination Business Enterprise)
 Small Business **HUD Section 3 Business**
- Certified by OMWBE (Washington State Office of Minority and Women's Business Enterprises)
 Self-Identified (SHA may request a signed statement re: self-certification)

Racial/Ethnic Status (check one):

- Caucasian (1)
 African American (2)
 Native American (3)
 Hispanic American (4)
 Asian/Pacific American (5)
 Hasidic Jews (6)

Method of Contract Payments: As outlined on the reverse side of this form, for contracts over one million dollars, SHA's method of contract payments is through an electronic virtual credit card issued by SHA's e-payables vendor, Bank of America. Unless SHA grants a waiver, Vendors will receive an enrollment form from SHA following issuance of a contract.

SIGN BELOW:

Signature of Authorized Representative of Vendor:

Date:

By signing immediately above, the Vendor hereby represents the following:

- The Vendor certifies that to the best of its knowledge and belief, neither it, nor any person/principal or firm which has an interest in the Vendor's firm, is ineligible to participate in a SHA contract, purchase order, direct pay or other transaction, pursuant to the Certification of Eligibility provision specified in the Vendor Fact Sheet Instructions, or;
- The Vendor will comply with SHA's General Terms and Conditions applicable to Purchase Orders, if the Vendor will be supplying goods and/or services through an SHA Purchase Order.

To obtain a copy of the General Terms and Conditions, call (206) 615-3379 or visit our Web site at

https://www.seattlehousing.org/sites/default/files/Purchase_Orders_Terms_Conditions.pdf

Vendor Fact Sheet Instructions

Thank you for your interest in doing business with the Seattle Housing Authority (SHA). We look forward to doing business with you. If you have any questions about completion of the Vendor Fact Sheet, please call us at (206) 615-3379.

In order for SHA to make payments to you or to procure goods or services from you, we need the information requested on the Vendor Fact Sheet, which also serves as a substitute IRS W-9 Form. The information about you will be entered into our computerized payment system and will allow us to make required reports to the Federal government about our business and payment transactions.

Substitute IRS Form W-9 Certification: In completing the Vendor Fact Sheet, you must sign the "Substitute IRS Form W-9 Certification" or backup withholding will apply. If you are subject to backup withholding and you are merely providing your correct taxpayer identification number to SHA, you must cross out the portion of the certification after the word "and" in line two, through the end of line five, before signing the form. Detailed instructions about IRS Form W-9 are included on the form, which may be obtained by calling our office at (206) 615-3379 or visiting the IRS web site at www.irs.gov.

Certification of Eligibility: In order to do business with SHA, the Vendor must be eligible to:

- 1) Be awarded contracts by any agency of the U.S. Government, HUD, or the State in which this Contract work is to be performed; or,
- 2) Participate in HUD programs pursuant to 24 CFR Part 24.

The websites to verify eligibility of the firm and its principals are: <https://www.sam.gov/portal/SAM> and http://portal.hud.gov/hudportal/HUD?src=/topics/limited_denials_of_participation. By signing the Vendor Fact Sheet, the Vendor understands that the certification of eligibility is a material representation of fact upon which reliance was placed when SHA agreed to enter into the transaction with the Vendor. SHA may require the Vendor to submit such certification on an annual basis depending on the terms of its contract or the frequency of its business transactions with SHA. If the Vendor subcontracts any portion of the work, the Vendor will be required to submit a similar certification of eligibility to SHA for any Vendor subcontracts. Any written contract executed between SHA and the Vendor shall include these provisions, which may also be referred to as Suspension/Debarment provisions.

Contract Payments: Unless SHA grants a waiver, its method of contract payment for contracts of one million or more is through its Bank of America e-payables program. Payments will be made electronically through a virtual Visa credit card. Benefits for using this method include reduced labor costs associated with the processing of checks and enhancing cash flow by eliminating float time associated with the mailing of checks. To learn more about the program, please click here or copy and paste the following URL into your browser: www.bankofamerica.com/epayablesvendors. For new vendors, SHA will automatically send an enrollment form upon contract award. If you have questions about the program, please contact Brenda Mix, SHA's Accounts Payable Manager, at 206-615-3421 or bmix@seattlehousing.org.

Small Businesses: The Vendor Fact Sheet also requests information about whether your business is owned and controlled by women or minorities, and/or is a small business. The following are definitions of these terms for your use. This information provides valuable information to SHA in its efforts to ensure its contracting program meets its diversity objectives and requirements.

- **WMBE:** Minority and women-owned business enterprises must either be self-identified or certified by, the Washington State Office of Women's and Minority Business Enterprises (OMWBE) to be at least fifty-one percent owned by women and/or minority group members.
- **Small Business:** A small business means a business concern, including its affiliates, that is independently owned and operated, not an affiliate or subsidiary of a business dominant in its field of operation, and qualified as a small business under the criteria and size standards in 13 CFR 121. Furthermore, a business is considered small according to the Small Business Administration's established guidelines provided to such businesses.
- **HUD Section 3 Business:** A business that is owned 51% or more by a Section 3 qualified person, or where 30% or more of the permanent, full-time employees of the business are Section 3 qualified persons, or where the business can provide evidence of a commitment to subcontract in excess of 25% of the amount of all subcontracts to other Section 3 certified businesses. A Section 3 qualified person must live in the metropolitan statistical areas identified on SHA's Section 3 form and whose income level meets or falls below the stated income limits.

Seattle Housing Authority

Section 3 Business Certification

The work to be performed under this contract is subject to the requirements of Section 3 of the Housing and Urban Development Act of 1968, as amended, 12 U.S.C. 1701u (Section 3). The purpose of Section 3 is to ensure that employment and other economic opportunities generated by HUD assistance or HUD-assisted projects covered by Section 3, shall, to the greatest extent feasible, be directed low-and very low-income persons, particularly persons who are recipients of HUD assistance for housing.

Section 3 Business Criteria: Your business is eligible for Section 3 Certification if it meets any one of the following criteria. If your business meets one or more of these criteria, please circle the applicable criteria.

1. Fifty-one percent or more of your business is owned and managed by a Section 3 qualified person or persons. (See qualification guidelines below) A completed and signed Individual Certification form for each Section 3 qualified person or persons is required to be submitted.
2. Thirty percent or more of your permanent, full time employees are Section 3 qualified persons. (When seeking certification under this criteria, please submit a listing of all current, permanent, full-time employees, as well as a completed and signed Individual Certification form for each Section 3 qualified employee.)
3. You can provide evidence of a commitment to subcontract in excess of 25 percent of the amount of all subcontracts to Section 3 certified businesses. (When seeking certification under these criteria, please consult with the Section 3 Coordinator regarding the documentation to be submitted.)

Section 3 Person Criteria: A Section 3 qualified person must:

- 1) Be a City of Seattle Housing Authority public housing resident; or
- 2) Live in the metropolitan statistical area (MSA) covering King, Snohomish, and Pierce counties, and,
- 3) Earn no more than the following amounts for the respective MSA area:

Region/Area	1 Person	2 Persons	3 Persons	4 Persons	5 Persons	6 Persons	7 Persons	8 Persons
King and Snohomish Counties	\$ 56,200	\$64,200	\$ 72,250	\$ 80,250	\$ 86,700	\$ 93,100	\$ 99,550	\$ 105,950
Pierce County	\$ 41,800	\$ 47,800	\$ 53,750	\$ 59,700	\$ 64,500	\$ 69,300	\$74,050	\$ 78,850

Section 3 Statement: Please check the appropriate box below.

- My business is eligible to be certified as a Section 3 business in accordance with the criteria circled above under Section 3 Business Criteria.
- My business is not a Section 3 business.

Signature:		Date Signed:
Name:	Title:	
Company Name:		
Address:		
Telephone Number:		

Note: If you certify above that your business is a Section 3 business, SHA will request documentation and additional information as may be reasonably required to certify whether your business qualifies as a Section 3 business.

Section 3 Resident Employment Plan

Section 3 of the Housing and Urban Development Act of 1968 (hereinafter “Section 3”) requires SHA, to the greatest extent feasible, to provide employment opportunities to “Section 3 residents.” Section 3 residents include residents of SHA communities and other low income residents of the metropolitan statistical area (hereinafter “MSA”) covering King, Snohomish, and Pierce counties. SHA residents, preferably residents of the SHA community in which the work is to be done, are favored over other low-income residents of the MSA.

For construction contracts only:

- Each bidder is required to submit with their bid package a plan which will result in the hiring of Section 3 residents to perform the work contemplated by the bid. SHA has established a goal that 100% of all new hires be Section 3 Residents to the greatest extent feasible.
- At a minimum, the Contractor and its subcontractors shall advertise new positions created in order to perform the work called for herein and will post notices to the Contractor’s commitments under Section 3 in conspicuous places at the work site. In addition, the Contractor must notify each labor organization with whom it or its subcontractors have a collective bargaining agreement or other understanding of these Section 3 commitments.

In order to fulfill its Section 3 obligations, the Contractor may work with service providers on site at various SHA communities including, but not limited to, Neighborhood House and the Employment Opportunities Center. The plan should specify the number of positions the Contractor expects will be created and what minimum qualifications and skills will be required in order to perform the positions. The plan, if applicable, should also address the Contractor/strategy for recruiting SHA residents for the available positions, which should include consultation with SHA’s Section 3 Coordinator.

1. How many new positions do you expect this contract will require you to create?

2. Describe each position and provide the name and provide the location of the person(s) taking applications for each such position.

3. What minimum skills will be required for each position?

4. Please describe any training opportunities which the contract may create and any agreements concerning training you have.

5. How will you advertise these positions to SHA residents?

If you have any questions about this form, please call Cary Calkins at (206) 588-4314.

SEATTLE HOUSING AUTHORITY

SUSPENSION AND DEBARMENT COMPLIANCE CERTIFICATE FOR CONTRACTOR

By signing below, the Contractor certifies that to the best of its knowledge and belief neither its firm nor any of its principals as named below are presently debarred, suspended, or have been declared ineligible or are excluded from participation in this transaction by any federal, state or local government.

Contractor's Firm Name: _____

Address: _____

City, State, Zip: _____

	PRINCIPAL(S) Name(s)	Title(s)
1		
2		
3		
4		
5		

Contractor's Signature	Printed Name	Title	Date

NOTE: This requirement applies to the Contractor's firm as well as its principals. Principal is defined in the regulation (2 CFR 180.995) as follows:

- 1) An officer, director, owner, partner, principal investigator, or other person within a participant with management or supervisory responsibilities related to a covered transaction; or
- 2) A contractor or other person, whether or not employed by the participant or paid with Federal funds, who-
 - a) Is in a position to handle Federal funds;
 - b) Is in a position to influence or control the use of those funds; or,
 - c) Occupies a technical or professional position capable of substantially influencing the development or outcome of an activity require to perform the covered transaction.

The federal websites to verify eligibility include: <https://www.sam.gov/portal/public/SAM/> and http://portal.hud.gov/hudportal/HUD?src=/topics/limited_denials_of_participation.

SEATTLE HOUSING AUTHORITY

SUSPENSION AND DEBARMENT COMPLIANCE CERTIFICATE FOR SUB-CONTRACTORS

The Prime Contractor may use this form if the Prime can verify that their Sub-Contractors named below, nor any of their principals are debarred, suspended or ineligible from involvement by Federal, State or Local Government. If the Prime is unable to verify this information, the Prime must send the previous SUSPENSION AND DEBARMENT COMPLIANCE CERTIFICATE FOR CONTRACTOR form to each sub- contractor to be completed and returned.

Prime Contractor’s Name: _____ certifies that neither any of the sub- contracting firms named below, nor any of its principals are debarred, suspended or ineligible from involvement by Federal, State or Local Government. I understand that the Seattle Housing Authority (SHA) relies on this certification and I understand that I am obligated to submit the following to SHA:

- A certification for any new sub- contractor hired after submission of this certification.
- A renewal certification for every sub- contractor on the anniversary of the Contract execution date if the Contract Time extends beyond one year.

(Note: In lieu of this certification, the Prime Contractor may elect to submit a separate certification signed by each sub- contracting firm to SHA as evidence of sub- contractor eligibility. It is the Prime Contractor’s responsibility to initiate, obtain, and provide all such individual sub- contractor certifications to SHA.)

Prime Contractor’s Signature	Printed Name	Title	Date

Sub- Contractor Firm Listing: (If sub- contractors are not involved in the project, please enter **NONE.**)

If additional pages are necessary, copy this form to ensure signed statement precedes any listing of sub- contractors. Please contact Greg Antoine at 206-615-3394 or by e-mail at Gregory.Antoine@seattlehousing.org if you have any questions regarding compliance with this requirement.

For-Profit Subgrantee and Contractor Certifications and Assurances

The Department of Housing and Urban Development (HUD) requires that all for-profit Subgrantees and Contractors on HOPE VI projects sign this “Certifications and Assurances” form certifying that they will comply with the specific federal requirements described below. The parties who must sign a “Certifications and Assurances” form are defined below:

- **Subgrantees:** These are for-profit organizations to which the Housing Authority (Housing Authority or Grantee) has awarded a grant from the HOPE VI grant that the Housing Authority received from HUD. The subgrantee is accountable to the Housing Authority for the use of the funds provided, but the Housing Authority is ultimately accountable to HUD.
- **Contractors:** This includes any for-profit contractor, consultant, service provider, or supplier that the Housing Authority contracts with for goods or services on any HOPE VI project.

.....

Certification and Assurance: The subgrantee or contractor executing this certification hereby assures and certifies that it will comply with all of the applicable requirements of the following, as the same may be amended from time to time, including adding appropriate provisions to all contracts between Grantee and for-profit Subgrantees or Contractors:

- (1) Administrative, contractual, or legal remedies in instances where contractors violate or breach contract terms, and provide for such sanctions and penalties as may be appropriate. (Contracts more than the simplified acquisition threshold)
- (2) Termination for cause and for convenience by the grantee or subgrantee including the manner by which it will be effected and the basis for settlement. (All contracts in excess of \$10,000)
- (3) Compliance with Executive Order 11246 of September 24, 1965, entitled “Equal Employment Opportunity,” as amended by Executive Order 11375 of October 13, 1967, and as supplemented in Department of Labor regulations (41 CFR chapter 60). (All construction contracts awarded in excess of \$10,000 by grantees and their contractors or subgrantees)
- (4) Compliance with the Copeland “Anti-Kickback” Act (18 U.S.C. 874) as supplemented in Department of Labor regulations (29 CFR part 3). (All contracts and subgrants for construction or repair)
- (5) Compliance with the Davis-Bacon Act (40 U.S.C. 276a to 276a-7) as supplemented by Department of Labor regulations (29 CFR part 5). (Construction contracts in excess of \$2000 awarded by grantees and subgrantees when required by Federal grant program legislation)
- (6) Compliance with Sections 103 and 107 of the Contract Work Hours and Safety Standards Act (40 U.S.C. 327-330) as supplemented by Department of Labor regulations (29 CFR part 5). (Construction contracts awarded by grantees and subgrantees in excess of \$2000, and in excess of \$2500 for other contracts which involve the employment of mechanics or laborers)

- (7) Notice of awarding agency requirements and regulations pertaining to reporting.
- (8) Notice of awarding agency requirements and regulations pertaining to patent rights with respect to any discovery or invention which arises or is developed in the course of or under such contract.
- (9) Awarding agency requirements and regulations pertaining to copyrights and rights in data.
- (10) Access by the grantee, the subgrantee, the Federal grantor agency, the Comptroller General of the United States, or any of their duly authorized representatives to any books, documents, papers, and records of the contractor which are directly pertinent to that specific contract for the purpose of making audit, examination, excerpts, and transcriptions.
- (11) Retention of all required records for three years after grantees or subgrantees make final payments and all other pending matters are closed.
- (12) Compliance with all applicable standards, orders, or requirements issued under section 306 of the Clean Air Act (42 U.S.C. 1857(h)), section 508 of the Clean Water Act (33 U.S.C. 1368), Executive Order 11738, and Environmental Protection Agency regulations (40 CFR part 15). (Contracts, subcontracts, and subgrants of amounts in excess of \$100,000).
- (13) Mandatory standards and policies relating to energy efficiency which are contained in the state energy conservation plan issued in compliance with the Energy Policy and Conservation Act (Pub. L. 94-163, 89 Stat. 871).

The information contained in this certification is true and accurate, to the best of my knowledge.

Name of Subgrantee or Contractor	Name and Contract Number:	
Signature of Authorized Certifying Official:	Title:	Date:

WARNING: Section 1001 of the Title 18 of the United States Code (Criminal Code and Criminal Procedure, 72 Stat.967) applies to this certification. 18 U.S.C. 1001, among other things, provides that whoever knowingly and willfully makes or uses a document or writing knowing the same to contain any false, fictitious or fraudulent statement or entry, in any matter within jurisdiction of any department or agency of the United States, shall be fined no more than \$10,000 or imprisoned for not more than five years, or both.

Return this form to:

Seattle Housing Authority
Attn: Greg Antoine, Purchasing
P.O. Box 19028
Seattle, WA 98109-1028



Address 190 Queen Anne Ave N
PO Box 19028
Seattle, WA 98109

Telephone 206-615-3300

TTY 1-800-833-6388

Website www.seattlehousing.org

Certification of Compliance with Wage Payment Statutes

The undersigned hereby certifies that the bidder is now, and in the three-year period immediately preceding the date of this bid solicitation (7/18/19) has been, in compliance with the responsible bidder criteria requirement of RCW 39.04.350(1)(g) and has not been found to have willfully violated any provision of RCW Chapters 49.46, 49.48, or 49.52 in a final determination by the Department of Labor and Industries or any court of limited or general jurisdiction.

I certify under penalty of perjury under the laws of the State of Washington that the foregoing is true and correct.

Bidder's Business Name

Signature of Authorized Official*

Printed Name

Title

Date

City

State

Check One:

Sole Proprietorship Partnership Joint Venture Corporation

State of Incorporation, or if not a corporation, State where business entity was formed:

If a co-partnership, give firm name under which business is transacted:

If a corporation, proposal must be executed in the corporate name by the president or vice-president (or any other corporate officer accompanied by evidence of authority to sign). If a co-partnership, proposal must be executed by a partner.